

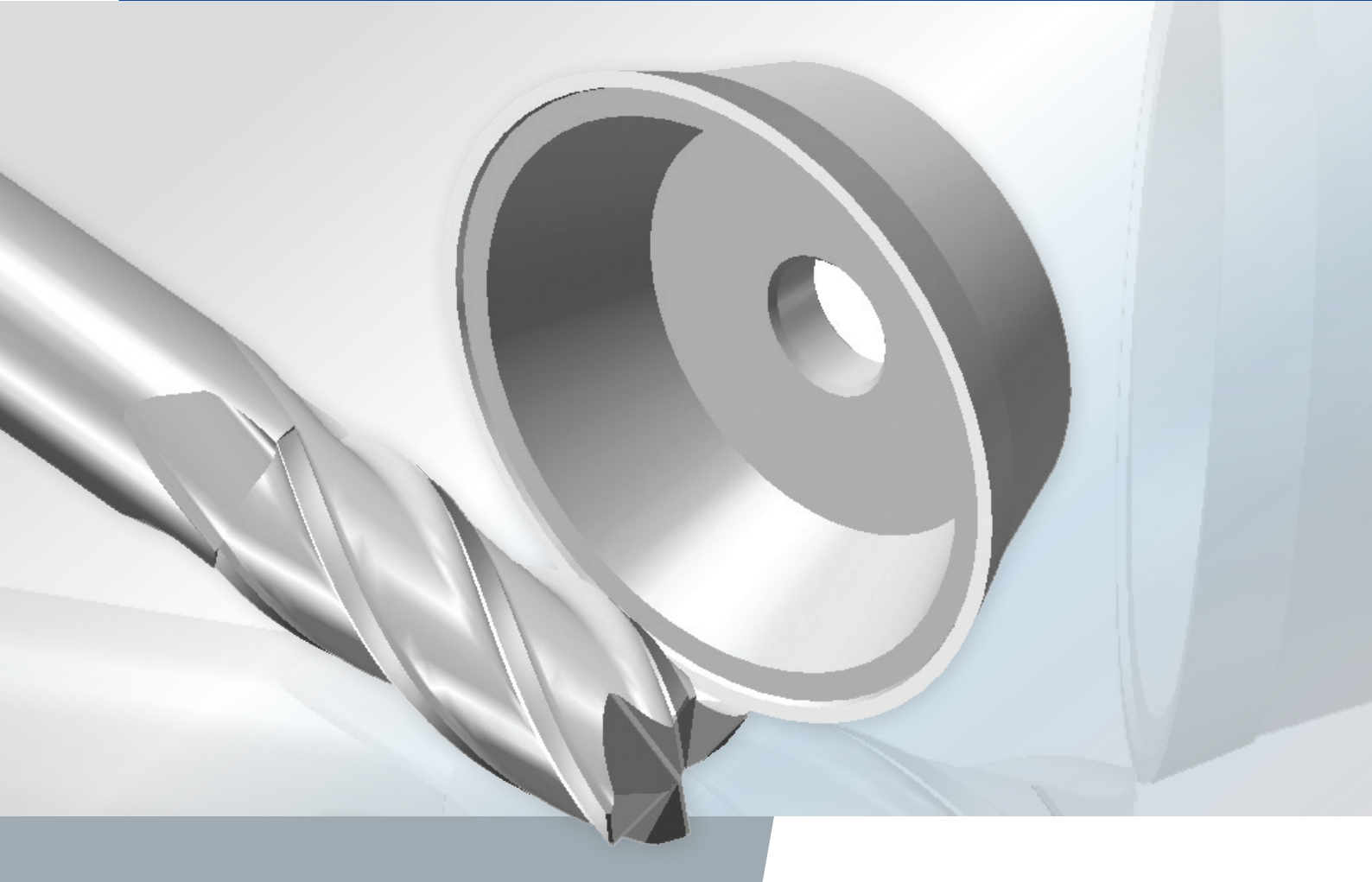

TOOLGAL
Innovative Diamond Tools

OD GRINDING - THE CHALLENGE



OD (Out Diameter,) Clearance Angel and End Face require wheels which enable the work piece to achieve excellent finishing, maximum surface Quality.

The requirements for surface quality have become much more stringent.
Toolgal wheels match this requirement

Toolgal bonds combine with accurately geometric design of the wheels enables the customer to meet the new demands.

Toolgal Standard Range for Grinding of Clearance Angles, End-faces

Suitable also for grinding OD, Gashing and radial clearances grinding and regrinding

Diamond wheels for tungsten carbide grinding	Wet Grinding		Dry Grinding	
High performance hybrid bond	RM6	D46-D64 C100		
Standard resin bond	CB4	D46-D64 C100-C125	CB	D64-D126 C75
Recommended cutting speed [m/s]	25-35		12-22	

CBN wheels for steel grinding	Wet grinding		Dry grinding	
High performance hybrid bond	RM9	B91-B107 V240		
Standard resin bond	CB951	B91-B126 V240-V300	CB964	B91-B126 V180
Recommended cutting speed [m/s]	25-45		25-35	

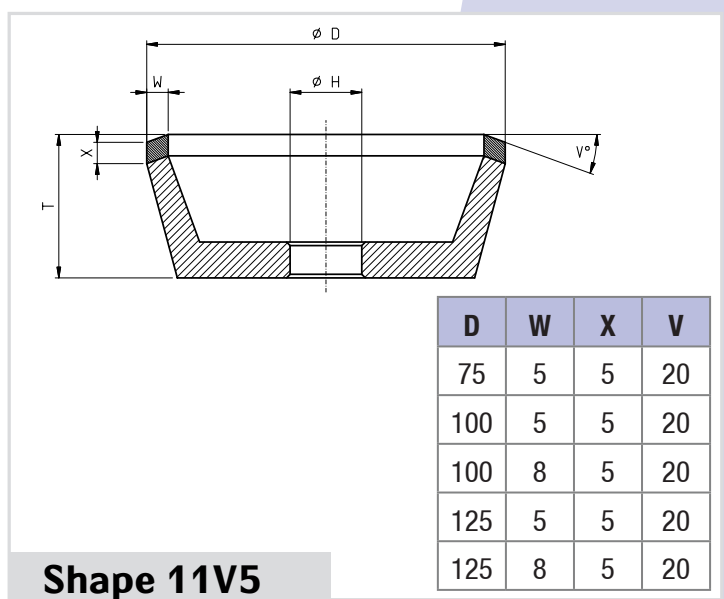
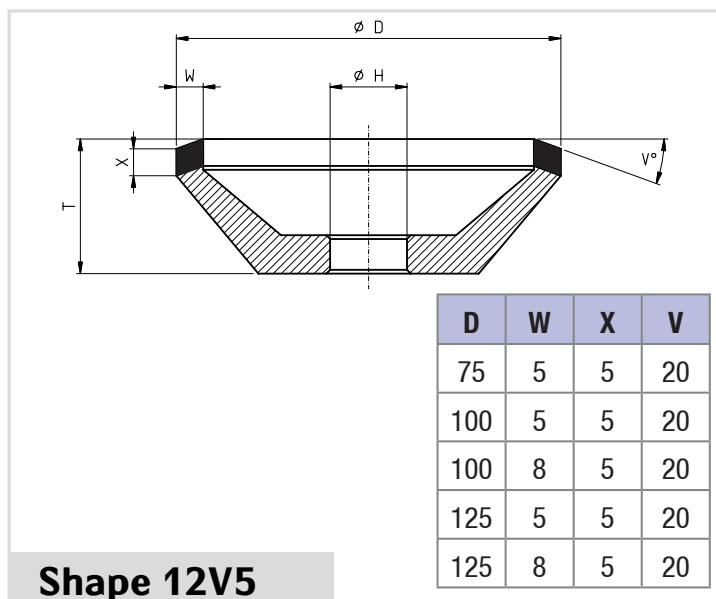
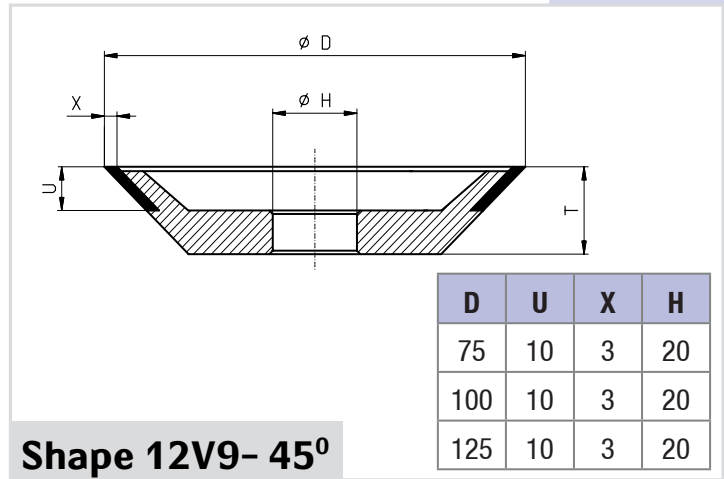
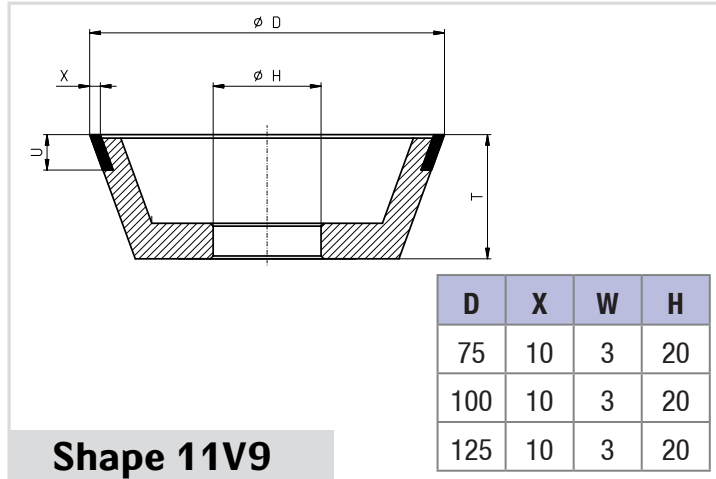

Toolgal Industrial Diamonds Ltd

Degania 'A' 15120, Israel

Tel: +972 4 6608445/6 Fax: +972 4 6752620

toolgal@toolgal.com

www.toolgal.com

