

DIAMOND TOOLS GRINDING WHEELS MACHINES

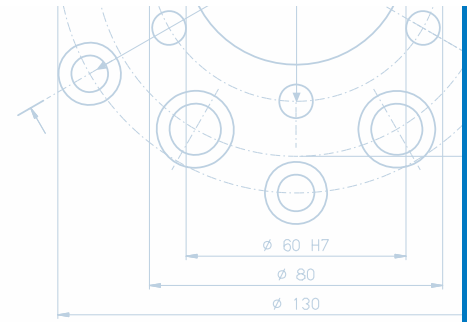

Diamond Tools



Construction applications

Wall Saws

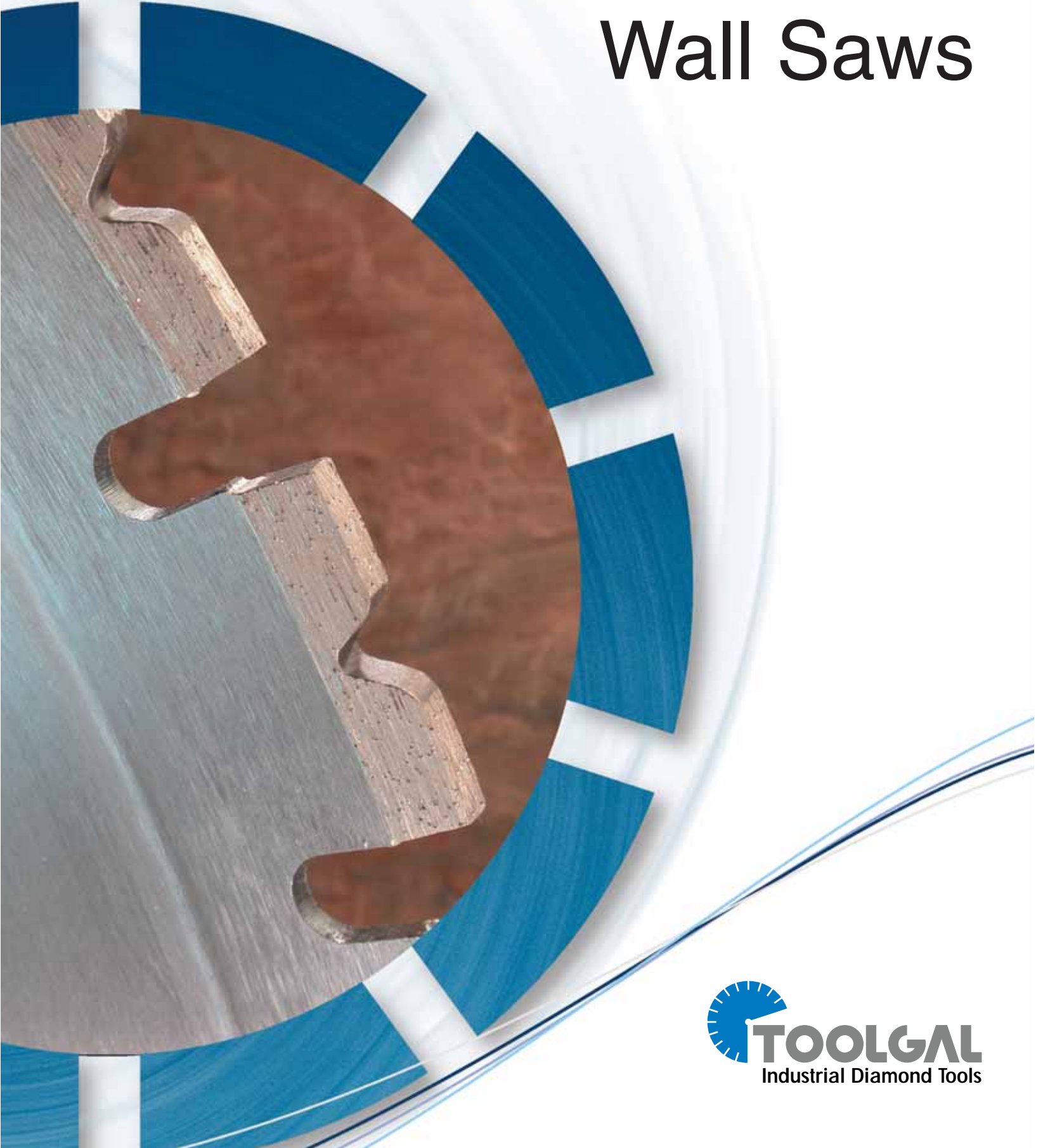



Wall Saws

Toolgal has developed its own special segments for the different machines and structures all over the world.

Toolgal segments are made in the standard thickness of 4" (450 mm - 750 mm) and 4.5 mm - 4.8 mm for all diameters. A special 5.6 mm thick segment for the step cutting usage is available too.

Toolgal sells three types of segments/blades structure-wise:

1. Regular segment in 40 mm long, to be brazed on 40 mm long landings.
2. Special V shape (Split segment) in 40 mm long, for the same cores.
3. Regular 20 mm long segments, to be brazed 2 segments on a 50 mm long landing.

Toolgal introduces new qualities every year for higher output and faster cutting, always using the best grits' qualities.

Toolgal sells all diameters in a regular brazing, to enable re-use of cores. Laser Welded blades can be ordered for up to 900 mm. Water cooling is recommended for these as well.

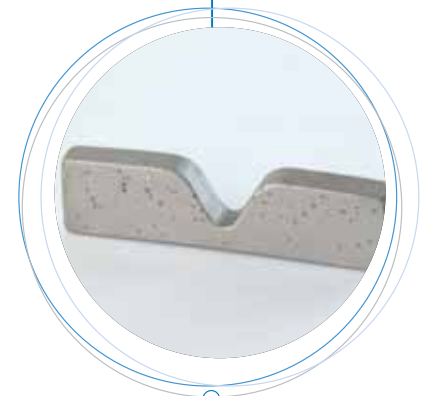
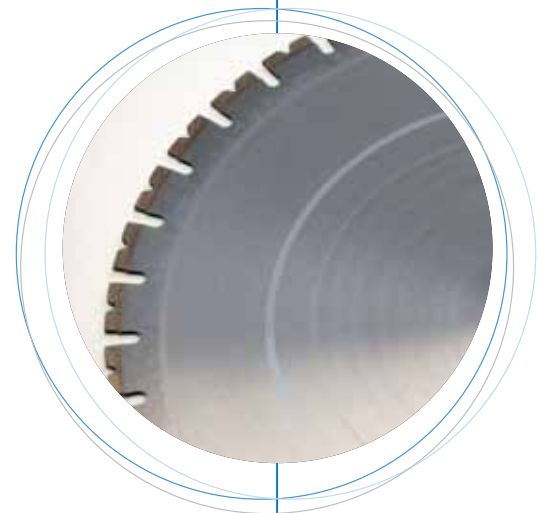

V shape (Split Segment)